

# AIR CONDITIONER

USER MANUAL

---

INVERTER SPLIT TYPE  
IVAS12EER3iPA / IVAS18EER3iPA



# E-WASTE DISPOSAL

## Environmental Compliances :

As per the rules laid down by the Government for Environmental Concern & Safety, your product has been made to comply and conform to the respective regulations as listed below. This product falls under the E-Waste (Management) Rules, 2016 with all amendments of Ministry of Environment, Forest & Climate Change.

## RoHS Declaration :

This Product is in conformity with requirements of Rule 16 of the E-Waste (Management) Rules, 2016 with all amendments. The content of hazardous substances with the exemption of the applications listed in SCHEDULE II of the E-Waste (Management) Rules, 2016 is as follows:

1. Lead (Pb): not over 0.1 % by weight;
2. Mercury(Hg): not over 0.1 % by weight;
3. Cadmium(Cd): not over 0.01 % by weight;
4. Hexavalent Chromium (Cr6+): not over 0.1 % by weight;
5. Polybrominated Biphenyls (PBBs): not over 0.1 % by weight;
6. Polybrominated Diphenyl Ethers (PBDEs): not over 0.1 % by weight.

## Do's and Don'ts for disposal of product :

### 1.) Do's :

- a) Always drop your used electrical/electronic products, defective spares or any accessories and packaging materials after the end of their life at the nearest authorized collection point/center.
- b) Make sure that your electronic products are recycled only by authorized recyclers/dismantlers.
- c) Segregate the packaging materials according to their respective waste disposal options and sorting for recycling.
- d) Protect the glass surface of any electronic product to avoid breakage.

### 2.) Don'ts :

- a) Never dismantle your electronic product yourself.
- b) Never sell or give E-Waste to informal and unorganized sectors like local scrap dealer/rag pickers.
- c) Never dump E-Waste in garbage bins or municipal solid waste stream.
- d) Do not dispose your product as unsorted municipal waste.



For more information on safe disposal and recycling, please call on Toll Free No.-**1800 267 4777** or visit our Website: **[www.ivas.homes/ewaste](http://www.ivas.homes/ewaste)**

# Operational Guidelines

The air conditioner must be grounded. Improper grounding may result in electric shock.



Please consult our company's authorised services provider for the same.

Be sure to pull out the power plug when not using the air conditioner for a long time.

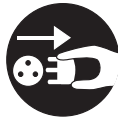

Otherwise, the accumulated dust may cause fire or electric shock.

Select the most appropriate temperature.



Don't leave windows and doors open for a long time while operating the conditioner.

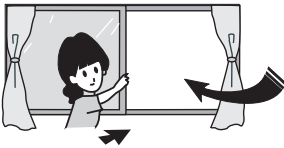

It can decrease the air conditioning capacity.

Don't block the air intake or outlet vents of both the outdoor and indoor units.

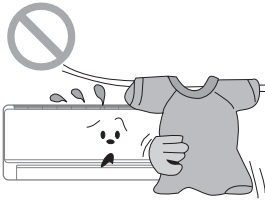

It can decrease the air conditioning capacity or cause malfunction.

Do not store combustible substances in the room where the air conditioner is installed and at least at distance of 15m. From the outdoor unit.

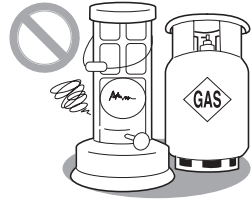

It can cause a fire explosion.

Please note whether the installed stand is firm enough or not.

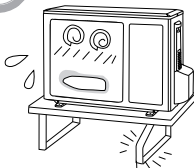

If it is damaged, it may lead to the fall of the unit and may cause injury.

Don't step on the top of the outdoor unit or place something on it.

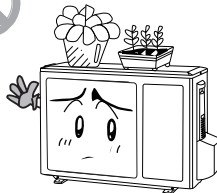

As falling off the outdoor unit can be dangerous.

Don't attempt to repair the air conditioner by yourself.

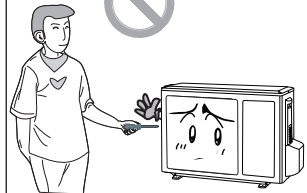

The wrong repair will lead to an electric shock or fire. You should contact our customer care for repair.

# Operational Guidelines

If the supply cord is damaged, it must be replaced.

Please contact our company's authorised service provider/dealer



The airflow direction can be adjusted appropriately.\*  
When on adjust the vertical airflow direction by adjusting the louvers of upward/downward direction, and then, hold two ends of left and right louver to adjust the horizontal airflow.

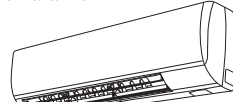

Louver of left/right direction      Louver of upward/downward direction

Feature varies model to model

Don't insert your hands or stick into the air intake or outlet vents. Otherwise it will cause accident.

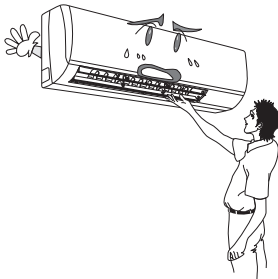

Don't blow the wind towards animals and plants directly. It can cause a bad influence on them.

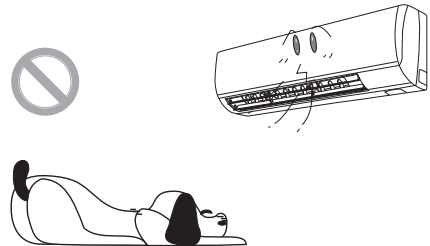

Don't apply the cold wind to the body for a long time directly.



It can cause health problems.

Don't use air conditioner for other purposes, such as drying clothes, preserving food, etc.

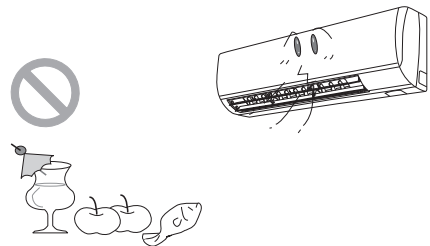

Splashing water on the air conditioner can cause an electric shock and malfunction.



Don't place a heat source near the air conditioner.

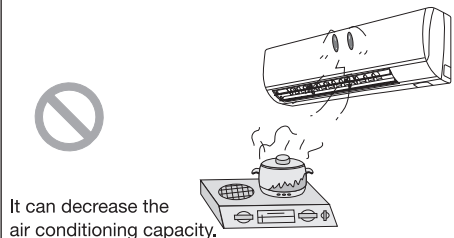

It can decrease the air conditioning capacity.

# Identification of Parts

## Indoor unit

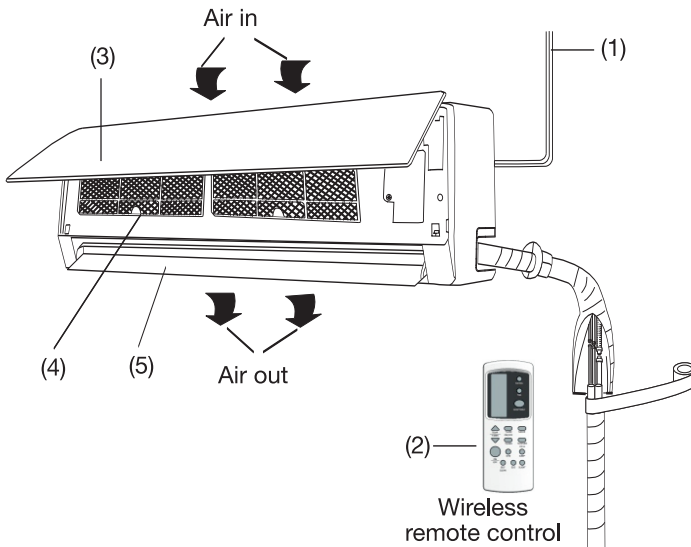

- 1) Power cable
- 2) Remote control
- 3) Front panel
- 4) Filter
- 5) Guide louver
- 6) Connection wire
- 7) Drainage pipe

## Outdoor unit

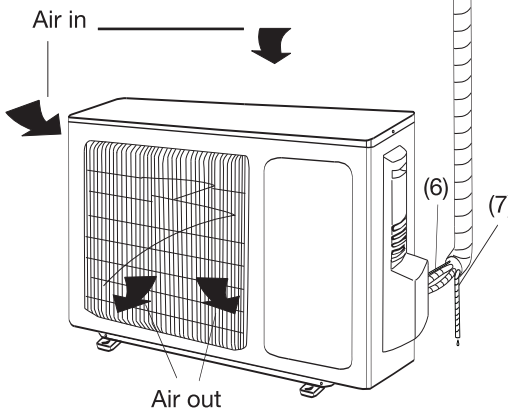

☑ The figures in this manual are based on the external view of a standard model. Consequently, the shape may differ from that of the air conditioner you have selected.

# Display Introduction

---

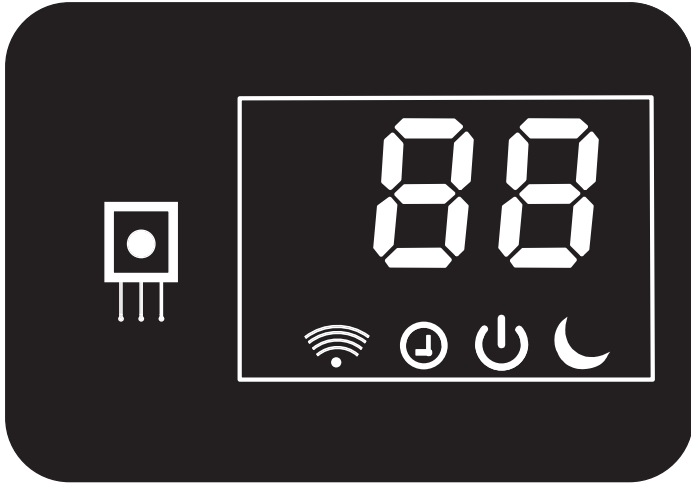

Display symbols:



Display Set Temperature



ON/OFF Button



Timer Indicator



Wi-fi Indicator



Sleep Mode Indicator

\* This display indicator is for presentation purpose only.

# Remote Controller

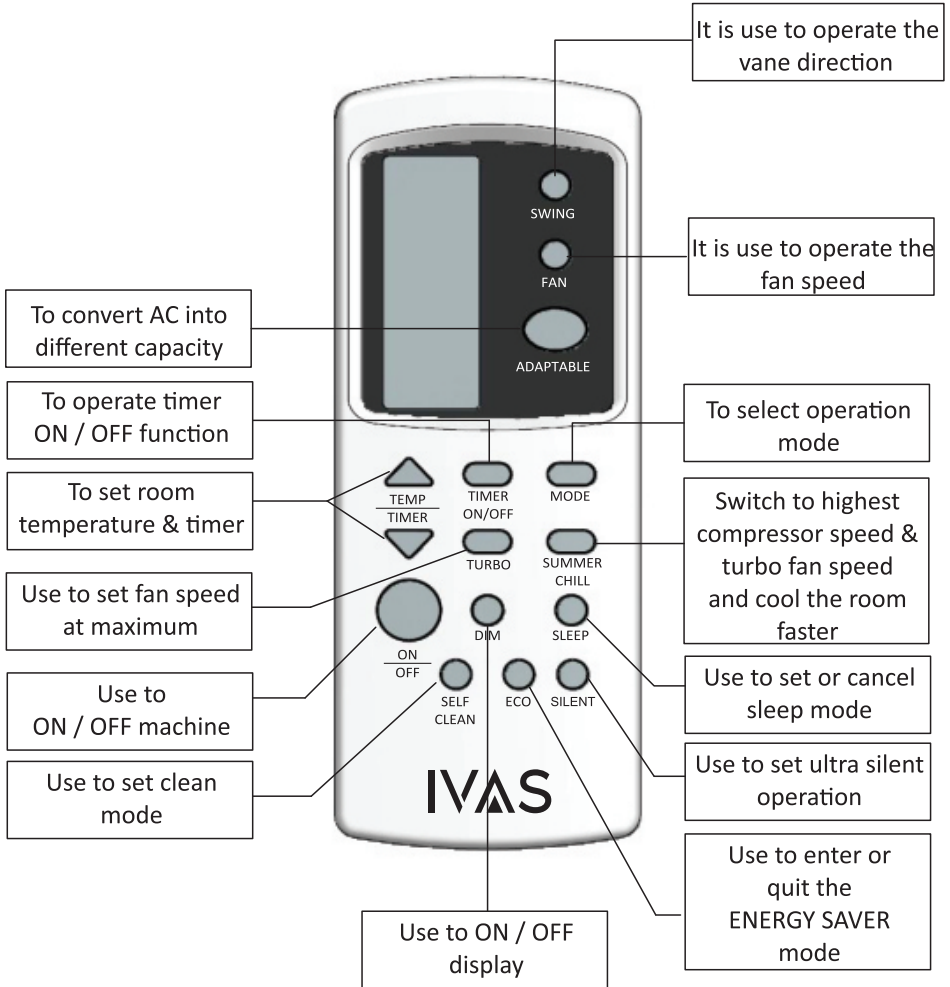

# Operation of wireless remote control

---

## Guidelines for Changing batteries

Lightly press location marked,  along the arrowhead direction to push the back cover of wireless remote hand set. (As shown in figure)

Take out the batteries. (As show in figure)

Insert two new AAA1.5V dry batteries and pay attention to the polarity. (As show in figure)

Replace the back cover of wireless remote hand set. (As show in figure)

### NOTE:

When changing the batteries, do not use the old or different batteries, otherwise, it can cause type malfunction of the wireless remote control.

If the wireless remote control will not be used for a long time, please take them out, and don't let the leakage liquid damage the wireless remote control.

It should be placed at least 1m away from the TV set or stereo sound set, if the wireless remote hand set is not functioning normally, take out the batteries, and after 30s reinsert them. If they are still not running normally replace them.

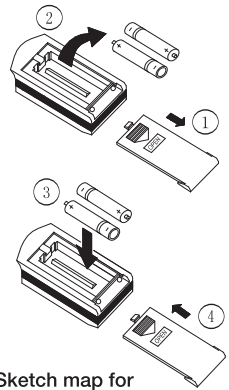

Sketch map for changing batteries

# Operating Instructions

---

## STANDBY ON/OFF

- This buttons is nominated by “ON/OFF” on remote control unit.
- It control of “Operation ON/OFF Switching” to the air conditioning.
- Only temperature 24°C displayed on remote LCD after inserted AAA batteries.

## Following 24°C logic is applicable when AC is operated in Cool mode :

If user has set the temperature below 24°C in Cool mode prior to switching off AC and then if AC is turned on by Remote, AC will start operating at 24°C temperature only.





If user has set the temperature 24°C or above 24°C in Cool mode prior to switching off AC and then if AC is turned on by Remote, AC will start operating at previous set temperature by user

## OPERATION MODES

---

This button is nominated by “MODE” on remote control unit. It changes the operation (operation switching) in cyclic way of air-conditioner (indoor unit) after each time of pressing this key.

---

Operation Mode	Corresponding Icons
COOL	
DRY	
FAN	
AUTO	

---

\* All feature may not be available, based on model selection.

## SUMMER CHILL

---

- This feature is applicable only in cool mode.
- This feature used for instant cooling. In this feature IDU fan run at turbo speed.
- Summer chill feature is applicable only for 20 minutes.
- After 20 minutes the summer chill feature will be cancelled automatically.

# Operating Instructions

---

## COOL MODE

---

- In this mode, the compressor cools the air by taking hot air out and blowing cold air inside the room.
- This is the most energy intensive mode on AC.
- Temperature can be varied from 16°C to 30°C by Pressing UP/DOWN keys.
- Fan speed can be varied by pressing fan speed key in the sequence of Low> Med> High>Auto On cyclic way.
- **Adaptable can be Enable/Disable by pressing Adaptable**  
**When Adaptable key is pressed, then icon shows c1, c2, c3 & c4**  
(Only if the feature is available.)
- ECO function can be Enable / Disable by ECO key.

## DRY MODE

---

- Set Temperature will be 24°C by default and it can't be varied by pressing temp up/down keys.
- Fan speed fixed to low speed and can't be varied.
- Turbo mode can't be set.
- Silent mode can't be set.
- Dim can be Enable/ Disable by pressing Dim key .
- Timer off can be Enable/ Disable by pressing Timer off key.
- Swing can be Enable/ Disable by pressing swing key

## FAN MODE

---

- Set Temperature will be 24°C by default and it can't be varied by pressing temp up/down keys.
- Fan speed can be varied by pressing fan speed key in the sequence of Low > Med > High cyclic way and Auto fan speed can't be set.
- Sleep mode can't be set by pressing sleep key.
- Silent mode can't be set.
- Eco mode can't be set.
- Dim can be Enable/ Disable by pressing Dim key.
- Timer off can be Enable/ Disable by pressing Timer off key.
- Swing can be Enable/ Disable by pressing swing key
- Turbo mode can't be set.

# Operating Instructions

---

## AUTO MODE

---

- Auto mode serves to achieve a specified temperature set point and maintain it.
- The Ac automatically adjust the compressor and fan speed in relation to the current room temperature.
- Set temperature will be 25°C by default and it can't be varied by pressing temperature up / down keys.
- Fan speed can be varied by pressing fan speed key in the sequence of Auto > Low > Med > High cyclic way.
- Swing can be Enable / Disable by pressing swing key.
- Turbo mode can't be set.

## SLEEP MODE

---

- Sleep will active when we press "sleep" key in cool mode from Handset.
- Sleep feature will active for 8 hours.
- After completing 8 hours, sleep feature will be deactivated and preset temperature will return to previous settings.
- Increment value will not go to memory.

## DIM FUNCTION

---

- Dim function can be Enable / Disable by pressing Dim key.
- When Dim key press once, the display will turns off. Pressing Dim key again, it will light up again.

## TURBO MODE

---

- Turbo feature activates by pressing turbo key in cool mode only
- Fan Speed will be turbo
- Swing will set at default position.
- During turbo set temperature can be changed by the user.

## SILENT OPERATION

---

- When Silent key is pressed by the user the IDU fan will run at minimum speed.
- Silent mode activates in cool mode only.

# Operating Instructions

---

## ECO FUNCTION

---

- ECO mode works by efficiently using compressor and fan so that minimal energy is consumed to achieve the temperature.
- When ECO is enable then fan speed is not changeable.
- When we set the temperature (between 16°C to 30°C) by pressing Eco key the default temperature would be 24°C .
- Set Eco function can be cancelled by itself button, on/off,summer chill key and Mode key.

## ADAPTABLE OPERATION (Only for Inverter models)

---

Press ADAPTABLE button repeatedly to select each step.

**Step 1.** Press Adaptable button one time AC capacity will be approx. 40% and remote shows C1 and indoor display also shows C1, if then temp change, the indoor display shows temp for 5 sec & then again C1.

**Step 2.** Press Adaptable button again one time AC capacity will be approx. 60% and remote shows C2 and indoor display also shows C2, if then temp change, the indoor display shows temp for 5 sec & then again C2.

**Step 3.** Press Adaptable button again one time AC capacity will be approx. 80% and remote shows C3 and indoor display also shows C3, if then temp change, the indoor display shows temp for 5 sec & then again C3.

**Step 4.** Press Adaptable button again one time AC capacity will be approx. 100% and remote shows C4 and indoor display also shows C4, if then temp change, the indoor display shows temp for 5 sec & then again C4.

**Step 5.** Press Adaptable button again one times, this mode gets cancel & Ac will run on its previous setting.

## SELF CLEAN

---

- Self-clean mode prevents the growth of airborne bacteria by removing moisture inside unit. It cleans and dries evaporator keeping AC fresh for the next operation.
- In this IDU display shows CL, louver swing to the minimum Position.
- At the same time, ODU will run for 10 minutes.
- After 10 minutes Outdoor unit will switch Off and Indoor unit fan will start for 5 minutes
- After 5 minutes the self clean feature will be cancelled and system will run at previous setting

# Operating Instructions

## OPERATION WITHOUT THE REMOTE CONTROL

If you have lost the remote control unit or if its malfunctioning, follow the steps below.

1. How to turn on the air conditioner:  
Open the front panel(if necessary), press the ON/OFF button with a ball-point.Then the air conditioner will automatically select the operation mode according to the room temperature.
2. How to turn off the air conditioner:  
Open the front panel(if necessary), press ON/OFF button with a ball-point.

Note: Do not press the ON/OFF button too long, as it may cause the air conditioner to operate abnormally.

## TIPS FOR ENERGY SAVING

If the air inlet and air outlet is blocked it might affect the normal heat exchange of the air conditioner and even cause damage to the appliance. When the air conditioner is operating in Cooling Mode during the daytime, please use a sun shield or curtains to keep from direct sunlight from entering into the the room. IF the walls and ceiling are irradiated by sunlight, it will take a long time to achieve the set temperature during cooling operation. Clean the air-filters at a certain time(about every two weeks ) and keep the air-filters clean to ensure normal heat exchange of the indoor unit. Keep the door and windows well closed when the air-conditioners is running to avoid loss of heat.

## FUNCTIONS AVAILABLE IN DIFFERENT MODES

	COOL	DRY	FAN	AUTO
SLEEP	√	X	X	X
DIM	√	√	√	√
SELF CLEAN	√	X	X	X
TURBO	√	X	X	X
FAN SPEED	√	X	√	√
SILENT	√	X	X	X
ADAPTABLE	√	X	X	X
TIMER	√	√	√	√
SWING	√	√	√	√

### \*\*BEE Test Setting by Remote

Full Load :- Set cool mode at high fan speed at 16 degree and then continuously press DIM key for eight times.  
Half Load :- Set cool mode at high fan speed at 17 degree and then continuously press DIM key for eight times.

\*\* Applicable to specific models

# Troubleshooting Chart

Fault	Symptoms	Probable cause	Trouble Point	Remedy
LESS COOLING	1 Supply Air is cold but room is not cooled	1 Excessive Cooling load	1 Room is too large for chosen capacity.	1 Recalculate the cooling load.
			2 Direct sunlight enters the room being cooled.	2 Do not install air conditioner near heater and other sources.
			3 Doors are opened and closed frequently or room contain too many persons	
			4 Heat sources such as heaters and cooking stoves, etc. are present.	
		2 Unsuitable installation location	1 Check if room air conditioner is installed in corner.	1 Change installation location.
			2 Check for any obstructing object in front of room air conditioner.	2 Remove any obstructing object.
	3 Insufficient air flow	1 Dust accumulates in the air filter	1 Wash out the dust on the air filter.	
		2 Dust adheres to fins which causes less air flow.	2 Clean the fins with brush and water.	
	2 Compressor is operating, but supply air is not cooled sufficiently	1 Defective refrigerating cycle	1 Refrigerant leakage from the brazed section in piping.	1 Check each section with halogen gas leak detector and repair it immediately when a leaking section is detected.
		2 Ambient condition	1 Compressor becomes overloaded and stops with the actuation of overload relay	1 Check for direct sunlight on air conditioner.
	3 Compressor stops soon after starting	1 Variation of power source voltage and power source capacity	1 Supply voltage is not in range of $\pm 10\%$ of rated	1 Use stabilizers for regulated power supply.
		2 Ambient condition	2 Compressor becomes overloaded and stops with the actuation of overload relay	2 Check for any sunlight on air conditioner.
		3 Compressor running capacitor becomes poor or disconnected	3 Check electrical wire and compressor running capacitor with capacitor.	3 Replace the defective capacitor.
		4 Defective refrigerating cycle and overload	4 Measure the voltage and current abnormality.	4 Repair refrigerating cycle and overload relay.
		5 Defective compressor	5 Check compressor winding resistance and compare with specification.	5 Replace any defective compressor.

# Troubleshooting Chart

DOES NOT COOL AT ALL	1	Fan motor does not run	1	Poor contact of plug, broken wire, switches thermistor	1	Measure the continuity of cord or voltage with a tester.	1	Replace any plug or part with poor contact or cord with broken arive.
			2	Fan motor failure	2	Check the broken connection in fan motor itself burnt and effect.	2	Check with DC motor testing jig if faulty replace the
	2	Fan motor is running but compressor does not operate	1	Variation of power source voltage and power source capacitor	1	Supply voltage is not in range of ~ 10% of rated.	1	Use stabilizers for regulated power supply.
			2	Ambient condition	2	Compressor becomes over-loaded and stops with the actuation of overload relay	2	Check for any direct sunlight on air conditioner.
			3	Compressor running capacitor becomes poor or disconnected	3	Check electrical wire and compressor running capacitor with capacitor.	3	Replace the defective capacitor.
			4	Defective refrigerant cycle or overload relay	4	Measure the voltage and current abnormality.	4	Repair refrigerating cycle and overload relay.
			5	Defective compressor	5	Check compressor winding resistance and compare with specification.	5	Replace any defective compressor.
	3	Compressor is operating but air is not cooled at all	1	Gas leakage	1	Measure the voltage and current abnormality.	1	Check each section with halogen gas leak detector and repair it immediately when a leaking section is detected.
			2	Compressor with defective valve			2	Replace any defective component.
	NOISE & VIBRATION	1	Compressor noise	1	Compressor with damaged piping suspension spring	1	Observe for any normal noise.	1
2		Knocking noise	2	Blower fan or pro fan hitting with foreign material	2	Check for any object around fan	2	Remove any foreign material from the system.
3		Reasoning noise due to vibration	1	Installation is not proper and parts of air conditioner are loose or internal parts of the compressor are damaged	1	Check the degree of vibration and installation with accuracy	1	Take proper measure to correct.
WATER DRIPPING	1	Water dripping inside room	1	Tilted unit installation	1	Check unit installation.	1	If necessary reinstall the unit
			2	Air filter may be dirty or clogged	2	Check air filter.	2	Clean dirty filter.

# Installation Instructions

## Installation diagram

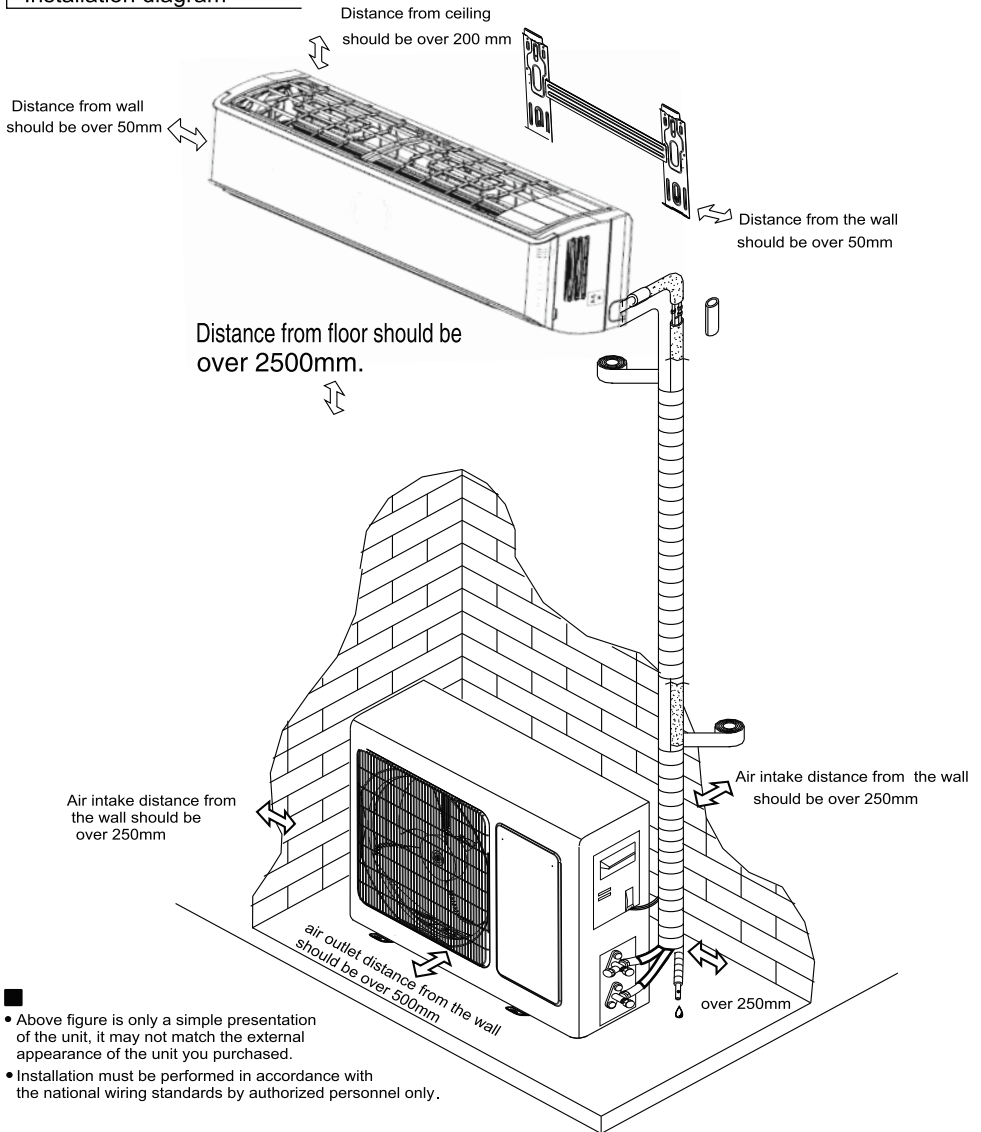

- Above figure is only a simple presentation of the unit, it may not match the external appearance of the unit you purchased.
- Installation must be performed in accordance with the national wiring standards by authorized personnel only.

# Installation Instructions

## Select the installation location

### Location for Installing Indoor Unit

- Where there is no obstacle near the air outlet and air can be easily blown to every corner.
- Where piping and wall hole can be easily arranged.
- Keep the required space from the unit to the ceiling and wall according to the installation diagram on previous page.
- Where the air filter can be easily removed.
- Keep the unit and remote controller 1m or more apart from television, radio etc.
- To prevent the effects of a fluorescent lamps, keep as far as possible.
- Do not put anything near the air inlet to obstruct it from air absorption.
- Where there is strong enough to bear the weight and is not tend to increase operation noise and vibration.
- Do not install above the entrance i.e. Door or in front of the door. installation area should have sufficient strength and durability.
- IDU should not install far away from desired cooling area.
- Do not place any electronic equipment below the IDU unit. Ex: LCD, Computer etc.

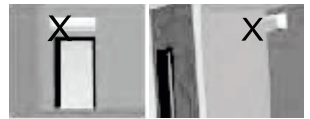
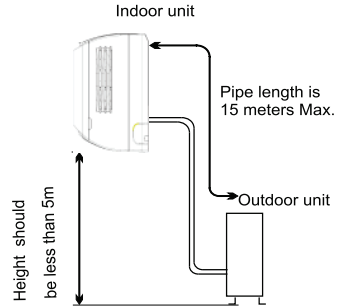

### Location for Installing Outdoor Unit

- Where it is convenient to install and well ventilated. Do not install ODU face to face. Avoid the installation in South and West direction.
- Avoid installing it where flammable gas could leak.
- Keep the required distance apart from the wall.
- Installation Connecting pipe length provided with this model to be considered as a standard length to connect Indoor & Outdoor units.
- Keep the outdoor unit away from a place of greasy dirt, vulcanization gas exit.
- Avoid installing it at the roadside where there is a risk of muddy water.
- A fixed base where is not subject to increasing operation noise.
- Where there is not any blockage for air outlet. (Don't install in shaft) Installation area should have sufficient strength and durability. To get optimize efficiency, install under shed.

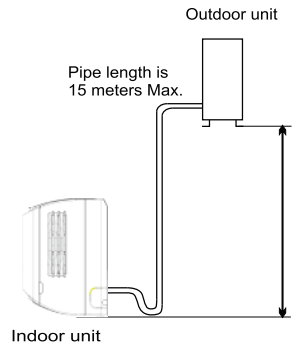

Limit of Tubing Length (m)	Limit of Elevation Difference H (m)	*Required amount of additional refrigerant exceeding 10m pipe length (g/m)
15	5	20

\*Be sure to add the proper amount of additional refrigerant. Failure to do so may result in reduced performance.

# Installation Instructions

Below declared Connecting pipe length to be referred as standard length for Model Sold without Connecting Pipe.

Model	Pipe length
1.0T	3 Meter
1.5T	3 Meter
2.0T	3 Meter

## Indoor unit installation

### 1. Installing the Mounting Plate

- Decide an installing location for the mounting plate according to the indoor unit location and piping direction.
- Keep the mounting plate horizontally with a horizontal ruler or dropping line.
- Drill holes on the wall for fixing the plate.
- Insert the plastic plugs to the hole, fix the mounting plate with tapping screws.
- Inspect if the mounting plate is well fixed. Then drill a hole for piping.

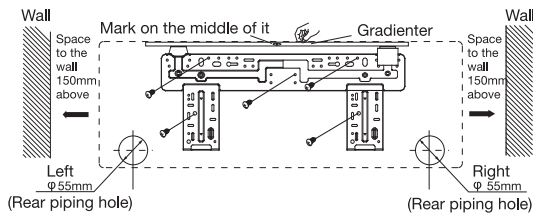

Note: The shape of your mounting plate may be different from the one above, but installation method is similar.

### 2. Drill a Hole for Piping

- Decide the position of hole for piping according to the location of mounting plate.
- Drill a hole on the wall with the help of drill machine. The hole should tilt a little downward toward outside.
- Install a sleeve through the wall hole to keep the wall tidy and clean.

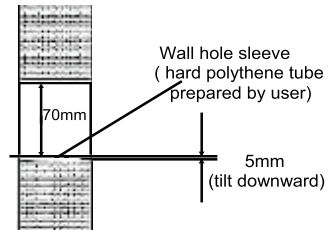

### 3. Indoor Unit Piping Installation

- Put the piping (liquid and gas pipe) and cables through the wall hole from outside or put them through from inside after indoor piping and cables connection complete so as to connect to outdoor unit.
- Check unloading piece off in accordance with the piping direction. (as shown below) and use tube bender the copper pipe.

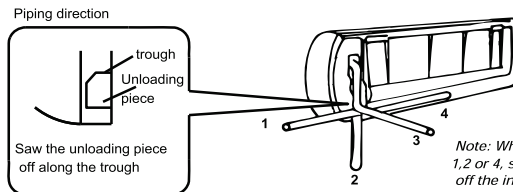

Note: When installing the pipe at the directions 1, 2 or 4, saw the corresponding unloading piece off the indoor unit base.

- After connecting piping as required, install the drain hose. Then connect the power cords. After connecting, wrap the piping, cords and drain hose together with thermal insulation materials. IDU should be mounted perfectly on mounting plate, Lock should be properly inserted.

# Installation Instructions

**\* Recommendation Piping Joints Thermal Insulation:**

Wrap the piping joints with thermal insulation materials and then wrap with a vinyl tape.

**Piping Thermal Insulation:**

- a. Place the drain hose under the piping.
  - b. Insulation material uses polythene foam over 6mm in thickness.
- Note: Drain hose is prepared by user.*

Drain pipe should point downward for easy drain flow. Do not arrange the drain pipe twisted, sticking out or wave around, do not immerse the end of it in water.

If an extension drain hose is connected to the drain pipe, make sure to thermal insulated when passing along the indoor unit.

When the piping is directed to the right, piping, power Cord and drain pipe should be thermal insulated and fixed onto the back of the unit with a piping fixer.

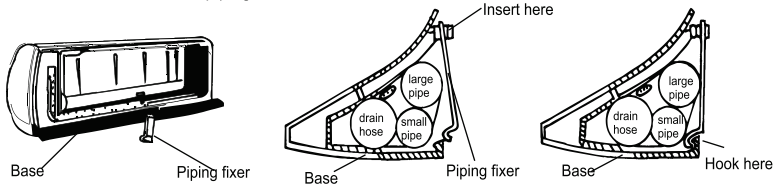
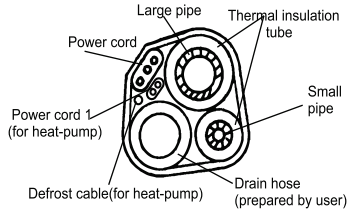

A. Insert the pipe fixer to the slot.

B. Press to hook the pipe fixer onto the base.

**Piping Connection:**

- a. Connect indoor unit pipes with two fix spanners. Pay special attention to the allowed torque as shown below to prevent the pipes, connectors and flare nuts from being deformed and damaged. Do not use adjustable wrenches.
- b. Pre-tighten them with fingers at first, then use the spanners.

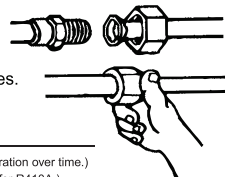

**CAUTION**

- Use the lare nut fixed to the main unit. (This is to prevent the lare nut from cracking as a result of deterioration over time.)
- To prevent gas leakage, apply refrigeration oil only to the inner surface of the flare. (Use refrigeration oil for R410A.)
- Use a torque wrench when tightening the lare nuts to prevent damage to the lare nuts and gas leakage.
- Align the centers of both lare and tighten the lare nuts 3 or 4 turns by hand, then tighten them fully with a spanner and torque wrench.

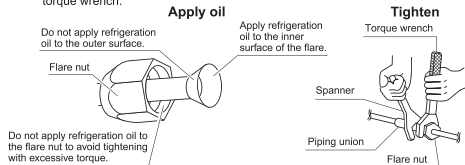

Model	Pipe Size	Torque	Nut Width	Min. Thickness
1.0 TR	Liquid Side (1/4")	15~20N.m	17 mm	0.6 mm
1.5 TR	Liquid Side (1/4")	15~20N.m	17 mm	0.6 mm
2.0 TR	Liquid Side (1/4")	15~20N.m	17 mm	0.6 mm
1.0 TR	Gas Side (1/2")	50~55N.m	24 mm	0.6 mm
1.5 TR	Gas Side (1/2")	50~55N.m	24 mm	0.6 mm
2.0 TR	Gas Side (5/8")	160~65N.m	27 mm	0.6 mm

\* Based on model selection.

Do not cut or short pipe length provided with product during installation, roll & fix pipe with ODU.

# Installation Instructions

## 4. Connecting of the Cable

### • Indoor Unit

Connect the power connecting cord to the indoor unit by connecting the wires to the terminals on the control board individually in accordance with the outdoor unit connection.

*Note: For some models, it is necessary to remove the cabinet to connect to indoor unit terminal.*

### • Outdoor Unit

- 1). Remove the access door from the unit by loosening the screw. Connect the wires to the terminals on the control board individually as the following.
- 2). Secure the power connecting cord onto the control board with cable clamp.
- 3). Reinstall the access door to the original position with the screw.
- 4) Use a recognized circuit breaker between The power source and the unit. A disconnection device to Adequately disconnect all supply line must be fitted.

### Caution:

1. Never fail to have an individual power circuit specifically for the air conditioner. As for the method of wiring, refer to the circuit diagram posted on the inside of the access door .
2. Confirm that the cable thickness is as specified in the power source specification.
3. Check the wires and make sure that they are all tightly fastened after cable connection.
4. Be sure to install an earth leakage circuit breaker in wet or moist area.
5. ODU Rubber pad to be used During Installation to Avoid Vibration & Noise.

### Cable Specifications

Capacity (Btu/h)	Power Cord		Power connecting cord			Main power supply(Note)
	Type	Normal cross-sectional area	Type	Normal cross-sectional area (Inverter)	Normal cross-sectional area (FS)	
12k	IS:694	1.0mm <sup>2</sup> X3	IS:694	1.0mm <sup>2</sup> X4	1.0mm <sup>2</sup> X3	To indoor
18k	IS:694	1.5mm <sup>2</sup> X3	IS:694	1.5mm <sup>2</sup> X4	1.5mm <sup>2</sup> X3	To indoor
24k	IS:694	2.5mm <sup>2</sup> X3	IS:694	2.5mm <sup>2</sup> X4	2.5mm <sup>2</sup> X3	To indoor

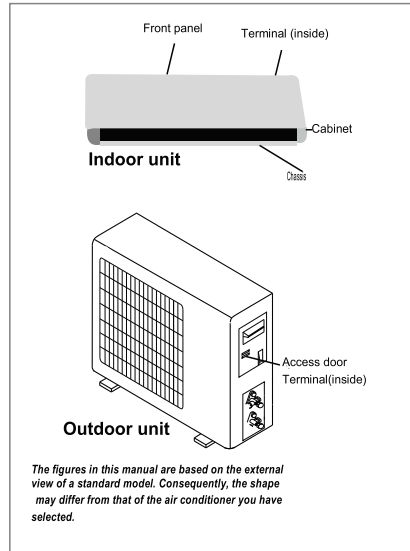

## ⚠ WARNING

- Do not use tapped wires, extension cords, or starburst connections, as they may cause overheating, electric shock, or fire.
- Do not use locally purchased electrical parts inside the product. (Do not branch the power for the drain pump, etc., from the terminal block.) Doing so may cause electric shock or fire.
- Do not connect the power wire to the indoor unit. Doing so may cause electric shock or fire.

# Installation Instructions

## Wiring Diagram

Make sure that the color of wires of the outdoor unit and the terminal No. are the same as those of the indoor unit.

- 12K,18K,24K Model

For above models, the power supply are connected from indoor unit.

## Wiring Diagram

INVERTER PCB WIRING DIAGRAM

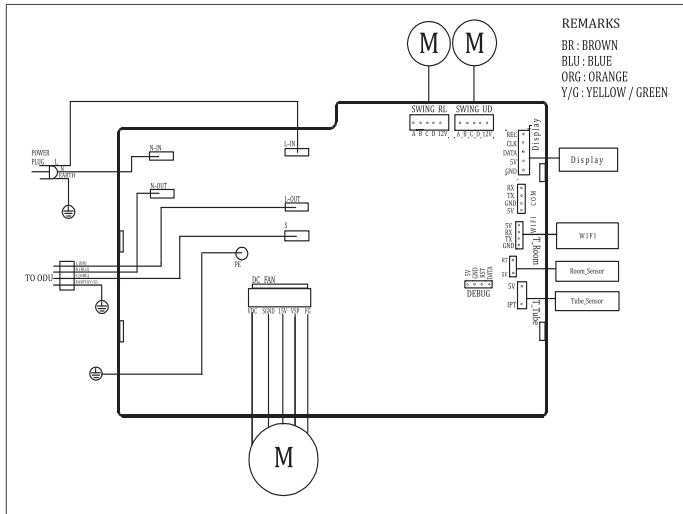

DISPLAY		FAULT DETAILS	
EE	Indoor machine EE fault	F5	Discharge temperature sensor fault
E1	Indoor fan fault	F7	Outdoor coil temperature sensor fault
E2	Indoor fan Zero crossing detection abnrml	F8	Outdoor ambient temperature sensor fault
E3	Indoor Coil temperature sensor fault	F9	Outdoor DC fan fault
E4	Indoor ambient temperature sensor fault	P1	Outdoor machine AC current protection
E6	Indoor and outdoor machine communication fault	P2	Compressor phase current protection
E0	Outdoor EE Fault	P3	Outdoor unit Over-voltage/Under-voltage protection
F1	Compressor starting abnormal (phase failure, reverse)	P5	IPM over high-temperature protection
F2	Compressor out-of-step fault	P6	Discharge temperature overheat protection
F3	IPM module fault or over current protect	P8	Cooling outdoor coil overheat protection

# Wiring Diagram

## Wiring Diagram For Fixed Speed Models

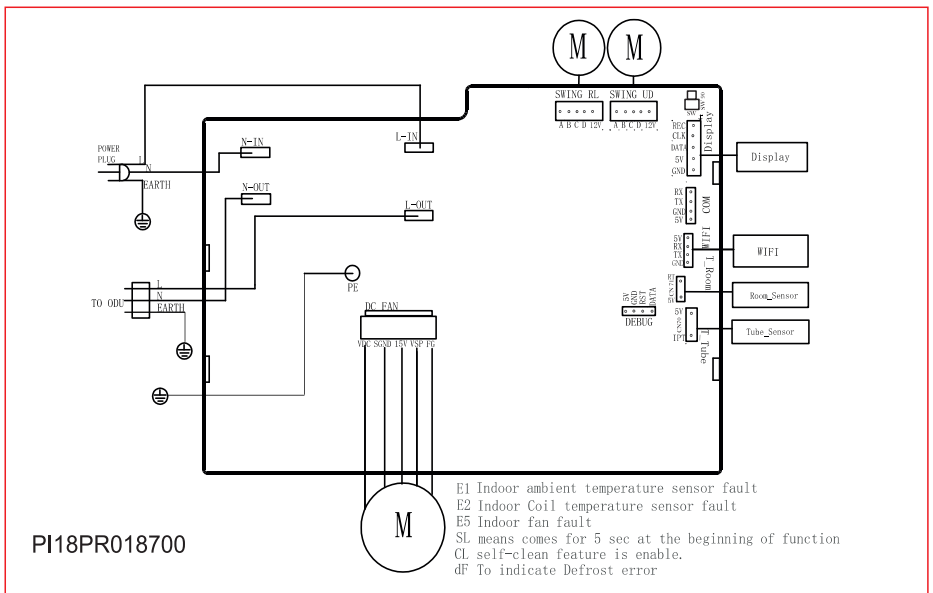

# Installation Instructions

## Outdoor unit installation

### 1. Install Drain Port and Drain Hose (for heat-pump model only)

The condensate drains from the outdoor unit when the unit operates in heating mode. In order not to disturb your neighbor and protect the environment, install a drain port and a drain hose to direct the condensate water. Just install the drain port and rubber washer to the chassis of the outdoor unit, then connect a drain hose to the port as the right figure shown.

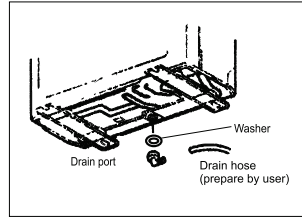

### 2. Install and Fix Outdoor Unit

Use rubber pad to fix with bolts and nuts tightly on a flat and strong floor. If installed on the wall or roof, make sure to fix the mounting stand and rubber pad well to prevent it from shaking due to serious vibration or strong wind.

### 3. Outdoor Unit Piping Connection

- Remove the valve caps from the 2-way and 3-way valve.
- Connect the pipes to the 2-way and 3-way valves separately according to the required torque.

### 4. Outdoor Unit Cable Connection (see previous page)

## Leak Test/Evacuation/Gas Charging

The air which contains moisture remaining in the refrigeration cycle may cause a malfunction on the compressor. After connecting the indoor and outdoor units, evacuate air and moisture from refrigerant cycle using a vacuum pump, as shown below.

Note: To protect the environment, be sure not to discharge the refrigerant to the air directly. See next page for air purging steps.

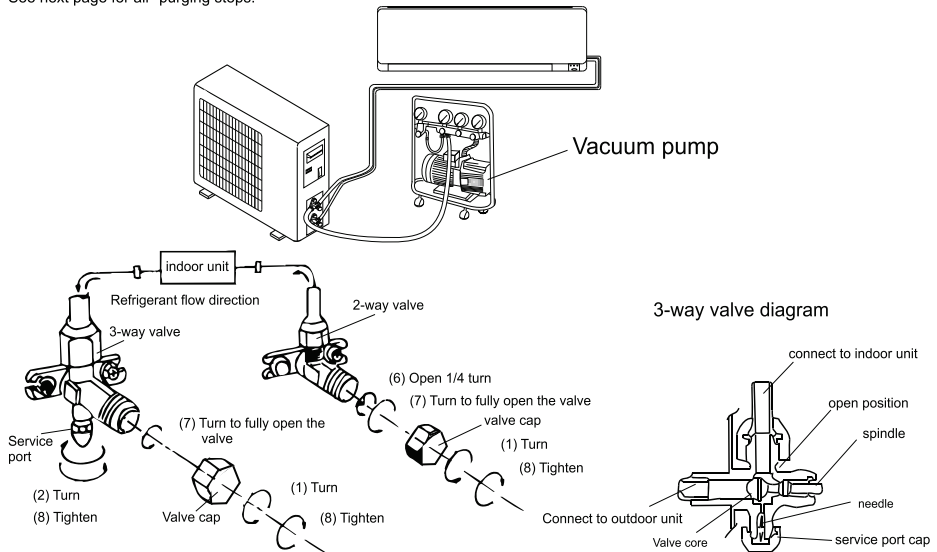

# Installation Instructions

---

## ***How to Purge Air Tubes:***

1. Connect IDU & ODU connecting piping.
2. Connect the Manifold Gauge & Vacuum Pump to the charging valve.
3. Do the system evacuate atleast for 30 minutes with two stage vacuum pump when reaching a vacuum of 10mm Hg absolute, switch off the pump & hold the vacuum for 5 minutes and check if the vacuum is breaking or not.
4. If vacuum breaks, then there is a leakage in system.
5. Rectify the leakage and do the vacuum again(Follow repeat of process)
6. If no vacuum breakage, open the spindles of 2-way & 3-way valves.  
Then again check leakage with soap suds

## **Notes**

- To guarantee the unit working normally, please read the manual carefully before installation, and try to install strictly according to this manual.
- Do not let air enter the refrigeration system or discharge refrigerant when moving the air conditioner.
- Earth the air conditioner properly.
- Check the connecting cables and pipes carefully, make sure they are correct and firm before connecting the power of the air conditioner.
- There must be an air-break switch.
- After installing, the consumer must operate the air conditioner correctly according to this manual, keep a suitable storage for maintenance and move of the air conditioner in the future.
- Caution: Mount with the lowest moving parts of indoor unit at Least 2.4m above floor or grade Level.
- Warning: Risk of electric shock can cause injury or death: Disconnect all Remote electric power supplies before servicing .
- The maximum length of the connecting pipe between the indoor unit and outdoor unit should be less than 5 meters. It will affect the efficiency of the air conditioner if the distance longer than that length.

■ • ***If the supply cord is damaged, it must be replaced by the manufacturer, its service agent or similarly qualified persons in order to avoid a hazard.***

■ • ***The appliance shall be installed in accordance with national wiring .***

## **Maintenance & Safety**

---

- Turn off Mains if not in use for long time.
- Clean filters, indoor and outdoor body periodically.
- Repaint the rubiginous place on outdoor unit to prevent it from spreading.
- Ensure Preventive Maintenance Service (PMS) of your AC twice a year to ensure it safe operation.
- Ensure no loose wires going to AC, they are properly secured to avoid chances of short circuit.
- Ensure service from company authorized service personnel and use company authorised service parts to ensure safe operation of your product.

# WARRANTY TERMS & CONDITIONS

M/s. Hella Infra Market Retail Private Limited (hereinafter referred to as **Hella Infra Market** or the **Company**) warrants that the **IVAS** brand Inverter Air Conditioner (Split Type) (hereinafter referred to as the "Unit") sold in India excluding the front grill, panel knobs, remote control, and add-on plastic parts, **applicable only to the original purchaser (first user of the Unit)**, subject to the Unit being duly registered with the **Company** at the time of installation or **within 15 days** from the date of invoice whichever is earlier. This warranty is in the nature of a contractual obligation between the **Company** and the **Purchaser**.

## SECTION 1 – WARRANTY COVERAGE

### 1. General Warranty – **Twelve (12) Months**

The Company warrants the Unit (excluding front grill, panel knobs, remote control and add-on plastic parts) against defects in manufacturing and materials for a period of **Twelve (12) Months** from the date of purchase by the original purchaser, **subject to proper registration at the time of installation or within 15 days from the date of invoice** whichever is earlier.

### 2. Extended Warranty

Extended Warranty if any, will be communicated by the Company from time to time.

## SECTION 2 – GENERAL TERMS AND CONDITIONS

1. The warranty shall be valid only for the aforesaid period of **Twelve (12) Months**, irrespective of whether the Unit has been in use or not, for any reason whatsoever, or whether the Unit has been relocated. The warranty does not cover accessories external to the equipment.

2. The warranty does not cover defects arising due to environmental damages such as but not limited to rust, oxidation of metal parts for whatever reasons, including use of the product in salty or chemical environments or any other place where the prevailing conditions act as a catalyst for the process of rusting.

3. This warranty is not applicable if the product is used for industrial purposes or unintended purposes (unless expressly permitted).

4. The warranty period specified above shall include time taken for repairs, replacements, breakdowns, and transit time. No separate notice of the expiration of the warranty period will be issued by the **Company**.

5. This warranty shall stand automatically terminated if the Unit is serviced, repaired, installed, de-installed, re-installed, or otherwise attended to by any person, organisation, or agency, or by the Purchaser himself, other than the Authorised Service Provider (ASP) of the **Company**.

6. Parts of the Unit replaced or repaired under the terms of this Product Performance Warranty Terms & Conditions are warranted only for the unexpired portion of the original warranty period.

7. For attending any service call under warranty beyond the municipal limits of the location where the Authorised Service Provider/Dealer of the **Company** is situated (outstation locations), all traveling and other incidental expenses incurred in connection with the visit of service personnel, technicians, etc. of the Authorised Service Provider/Dealer shall be borne by the Purchaser and paid in advance. Such charges shall be communicated in advance and accepted by the **Purchaser** prior to service. Additionally, any cost incurred by the Authorised Service Provider in relation to the transportation of the Unit or any part thereof from such outstation locations and its return to the original location shall be borne by the **Purchaser**.

# WARRANTY TERMS & CONDITIONS

8. The warranty does not cover any defects caused by acts of God or misfeasance/physical damage/abuse by service providers or customers such as but not limited to loss of refrigerant caused due to sabotage, loosening of flare nut, improper handling or treatment, carelessness, accident, fire, flood, earthquake, any natural calamity, force majeure, etc., or any corrosive action on the original refrigerant pipes, fittings, valves, etc., for whatever reasons.
9. In the event of relocation of the Unit during the warranty period, the warranty shall become null and void unless prior written communication is provided to the Company and the Company has given its written consent for such relocation. On receipt of such information, the Company or any of its Authorised Service Providers shall arrange for de-installation of the Unit on a chargeable basis. For reinstallation, the Purchaser must register a call with the Company; installation and accessory costs, if any, shall be charged extra at the new location. If the Unit is relocated without the consent of the Company, any damage, repair, or replacement costs arising from such relocation shall not be covered under this warranty.
10. It shall be the absolute discretion of the Company to:
  - a. Carry out the repairs or replacement of parts whether at the site of installation or at any of its Authorised Service Centre; and
  - b. Assign the job to either the Company's service personnel or its Authorised Service Provider.
11. This warranty is in the nature of and for the purpose set forth herein. The Company's total aggregate liability shall not exceed the purchase price of the Unit or components. In particular, the Company shall not in any event be liable for direct, indirect, incidental, or consequential loss or damages to either the Purchaser of the Unit and/or their property or any other third party.
12. The air conditioner is designed to operate at a range of 230 V  $\pm$  10%. Any failure caused due to operation outside this range shall not be covered under this warranty. The Purchaser shall ensure that a stabiliser from a reputed manufacturer is installed in areas where voltage is not available within this range.
13. Since products are continuously being upgraded based on the Govt standards and energy efficiency ratings, we recommend that products are contemporary and can be covered effectively under the warranty offered by the Company. To facilitate this, we have already recommended our dealers to revalidate stocks which are greater than 6 months from the date of manufacture and consumers are advised to check the manufacturing date or revalidation date as 12 months warranty from date of original purchase is conditional to 18 months from the date of manufacture or revalidation date.

The Purchaser shall preserve the original purchase invoice and produce the same for verification as and when required.

## SECTION 3 – CONDITIONS PRECEDENT FOR CLAIMING WARRANTY

This warranty can be claimed only upon satisfaction of all of the following conditions/obligations to be fulfilled by the Purchaser:

- a. The Unit is purchased from an Authorised Dealer of the **Company**.
- b. Installation of the Unit is carried out by **IVAS's** Authorised Service Provider (ASP) pursuant to a duly registered installation request with the Company.
- c. After purchase and immediately on installation or within 15 days from the date of Invoice whichever is earlier, the Purchaser registers the Unit with the Company by scanning the QR code available on the Unit, along with the model number and serial number or other methods such as through **IVAS** website and/or customer care number.

# WARRANTY TERMS & CONDITIONS

d. Although the Product Performance Warranty Terms & Conditions are included in the Owner's Manual provided with the product, the Company shall also electronically send the service request modes available along with the Product Performance Warranty Terms & Conditions to the registered mobile number of the customer given at the time of registration of the product.

e. The Purchaser avails two (2) Preventive Maintenance Services (PMS) from the Authorised Service Provider of the Company by registering PMS requests with the Company in the first year free of cost, and thereafter ensures that PMS is conducted twice annually along with maintaining proof of such PMS.

f. No damage is caused due to accident, mishandling, tampering with installation, negligence, or failure to follow instructions as provided in the user manual.

g. No damage is caused due to improper electrical supply or defective external electrical circuits outside the Unit.

h. No tampering of the Unit, or repairs or services availed from an unauthorised person.

i. The serial number of the Unit or any part thereof is not damaged, defaced, altered, obliterated, tampered with, or removed for any reason whatsoever.

j. No unauthorised relocation of the Unit from its original place of installation or reinstallation.

k. The warranty is valid only on GST invoices issued to the Purchaser by the authorised dealer of the Company.

## **SECTION 4 – WARRANTY EXCLUSIONS**

This warranty shall NOT be applicable in the following circumstances:

a. The Unit is not purchased from an Authorised Dealer of the Company.

b. Installation is not carried out by the Company's Authorised Service Provider (ASP) pursuant to a duly registered installation request.

c. The Purchaser fails to register the product with the Company at the time of installation or within 15 days from the date of invoice whichever is earlier.

d. The Purchaser fails to avail two (2) Preventive Maintenance Service (PMS) in the first year and subsequently twice every year through the Company's Authorised Service Provider along with maintaining record of such PMS. PMS is recommended for long terms safe operation of AC.

e. Any accessories, components, or materials not supplied or installed by the Company or its Authorised Service Provider (ASP), including piping, wiring, stabilisers, stands, or fittings, shall not be covered under this warranty. Any damage arising therefrom shall be chargeable and shall be paid by the Purchaser.

f. The warranty does not cover defects arising due to rust, oxidation of metal parts for whatever reasons, including use of the product in salty or chemical environments or any other place where the prevailing conditions act as a catalyst for the process of rusting. The warranty does not cover any defect arising due to sabotage, improper handling or treatment, carelessness, accident, fire, flood, earthquake, any natural calamity, force majeure, etc., This warranty is not applicable if the product is used for industrial purposes.

g. Any damage caused due to accident, mishandling, improper installation, negligence, or failure to follow instructions in the user manual.

h. Any damage arising from improper electrical supply or defective external electrical circuits.

i. Any tampering, repair, or service undertaken by unauthorised personnel.

# WARRANTY TERMS & CONDITIONS

j. Any tampering with, alteration, defacement, or removal of the serial number of the Unit or its components or if the serial number of the Unit is unreadable.

k. Any unauthorised relocation or reinstallation of the Unit from its original installation site.

l. Use of the product for industrial purposes.

m. Since products are continuously being upgraded based on the Govt standards and energy efficiency ratings, we recommend that products are contemporary and can be covered effectively under the warranty offered by the company. To facilitate this, we have already recommended our dealers to revalidate stocks which are greater than 6 months from the date of manufacture and consumers are advised to check the manufacturing date or revalidation date as 12 months warranty from date of original purchase is conditional to 18 months from the date of manufacture or revalidation date.

## SECTION 5 – MISCELLANEOUS TERMS AND CONDITIONS

1. No employee, authorised dealer, authorised service personnel, or authorised representative of the Company is authorised to modify, alter, waive, or vary any of the terms and conditions of this Product Performance Warranty Terms & Conditions.

2. All electronic records maintained by the Company, including but not limited to product registration details, installation records, service history, PMS records, and purchaser/customer communications, whether generated through **IVAS** website, or customer care number, shall be deemed true and correct and shall constitute final and conclusive evidence for all purposes under this Product Performance Warranty Terms & Conditions.

3. Except as expressly provided herein, all other warranties, whether express, implied, statutory, or otherwise, including merchantability and fitness for a particular purpose, are expressly disclaimed to the maximum extent permitted by law.

4. This warranty shall be deemed to have been issued at **Mumbai**. Therefore, the Consumer Court in **Mumbai** or the High Court in **Mumbai** shall have exclusive jurisdiction on all matters covered by or disputes arising from this Product Performance Warranty Terms & Conditions. The original purchaser alone shall have cause of action arising out of this transaction.

5. If any term is held invalid, the remaining terms shall continue in full force.

6. By purchasing the Unit and/or registering the Unit with the Company, the Purchaser acknowledges that they have read, understood, accepted and agree to be bound by the present Product Performance Warranty Terms & Conditions.

7. This document constitutes the entire Product Performance Warranty Terms & Conditions between the parties and supersedes all prior representations. No oral representations shall be binding.

Warranty Registration Card

Serial No.

**Customer Details**

Title: Mr  Ms  Mrs  M/s

Name:

Residence Address:

Dist:  Pin:

State:  Occupation:

Tel: (  )  Res: (  )

Mobile No:  Email:

**Product Details**

Model No:

Serial No:

Please Refer Sticker On Back Cover Of Your Product

Purchase Date:     
Day Month Year

Bill No.

**Dealer's Name & Address**

Signature

I Accept The Terms And Conditions of The Warranty

Customer Signature

Thank you for selecting a World Class product and we assure you that it will perform as per your expectations. We thank you for taking your time to complete this form. All Information Provided by You will be Kept Confidential. **(Please fill In, Tear off, Fold and Mail this form to Reach us within 15 days of the Product Purchase.)**

**We welcome your Valuable Suggestions, if any, to Improve our Products and Services :**

---



---

**FOR OFFICE USE ONLY**

Customer Code:

Branch:

# IVAS

— Ghar Dhadakne Do —

Tiles | Quartz | Sanitaryware | Bath Fittings | Fans | Lighting | Appliances  
Modular Kitchens | Laminates | Designer Hardware

**HELLA INFRA MARKET RETAIL PRIVATE LIMITED**

INFRA.MARKET House, Olethia Business Spaces, Road No 16Z,

Opp. Ashar IT Park, Wagle Industrial Estate, Thane (W) 400604

[www.ivas.homes](http://www.ivas.homes) | [support@ivas.homes](mailto:support@ivas.homes)

 **77740 70004**

Powered by

**INFRA.MARKET**

0